



Post-Graduate Certificate in Psychosynthesis Leadership Coaching

September 2016



Unit 3: Coaching Psychology

November 2016



Day One

- ❖ Check-in, reflecting on learning since the last workshop
- ❖ Overview of the 3 days

Unit 3 Overview	Day One	Day Two	Day Three
Check-in/review	Check-in and reflection.	Check-in and reflection.	Check-in and reflection.
Session 1	The coaching psychology landscape and the evolution of coaching	Academic brief: PGCPCL requirements and procedures	Overview of psychospiritual and transpersonal psychologies
Break			
Session 2	Model of psychospiritual development; pre-personal, personal and transpersonal levels. The pre-trans fallacy.	Personal: Introduction to Humanistic Psychology: Gestalt, TA, NLP, etc.	Transpersonal: working with the I-Self and Crisis in coaching - triads practical work
Lunch			
Session 3	Prepersonal: Attachment theory, anxiety and neurosis; Transference and counter-transference; Projection and introjection	Personal: Gestalt – group session practical work	Crisis in coaching - practical work plenary
Break			
Session 4	Prepersonal: - triads practical work	Personal: Positive Psychology and Neuro-psychology	Transpersonal: The Will Working with Will in coaching; group fishbowl exercise and plenary
Break			
Session 5	Prepersonal: -practical work plenary	Personal: Integration within the psychosynthesis context of trifocal vision	Homework
Check-out/ completion	Check-out	Check-out	Check-out

Unit 3: Coaching Psychology: Key topics

Coaching psychology

- ❖ The evolution of coaching
- ❖ The coaching psychology landscape

Model of psychospiritual development

- ❖ Pre-personal, personal and transpersonal levels
- ❖ The pre-trans fallacy

Prepersonal psychology

- ❖ Attachment theory
- ❖ Anxiety and neurosis
- ❖ Transference and counter-transference
- ❖ Projection and introjection

Personal psychology

- ❖ Introduction to Humanistic psychology
- ❖ Gestalt Psychology
- ❖ Positive Psychology
- ❖ Neuro-psychology

Psychospiritual/transpersonal psychology

- ❖ Overview of psychospiritual and transpersonal psychologies
- ❖ Working with the Self/self and Crisis in coaching
- ❖ Working with Will in coaching

Coaching Competencies

- ❖ Impact and influence
- ❖ Creating awareness

The evolution of coaching

- ❖ Origins
- ❖ Growth and change
- ❖ Establishment and professionalisation
- ❖ Maturing and developing market
- ❖ The wider context and marketplace
- ❖ Key issues and possible future evolution

The coaching psychology landscape

- ❖ Coaching psychology and psychological coaching
- ❖ Conventional/established/partial vs post-conventional/emerging/holistic
- ❖ British Psychological Society – special interest group in coaching psychology
- ❖ Most prevalent coaching psychologies?
- ❖ Coaching psychology options?

Structure of the psyche – Roberto Assagioli

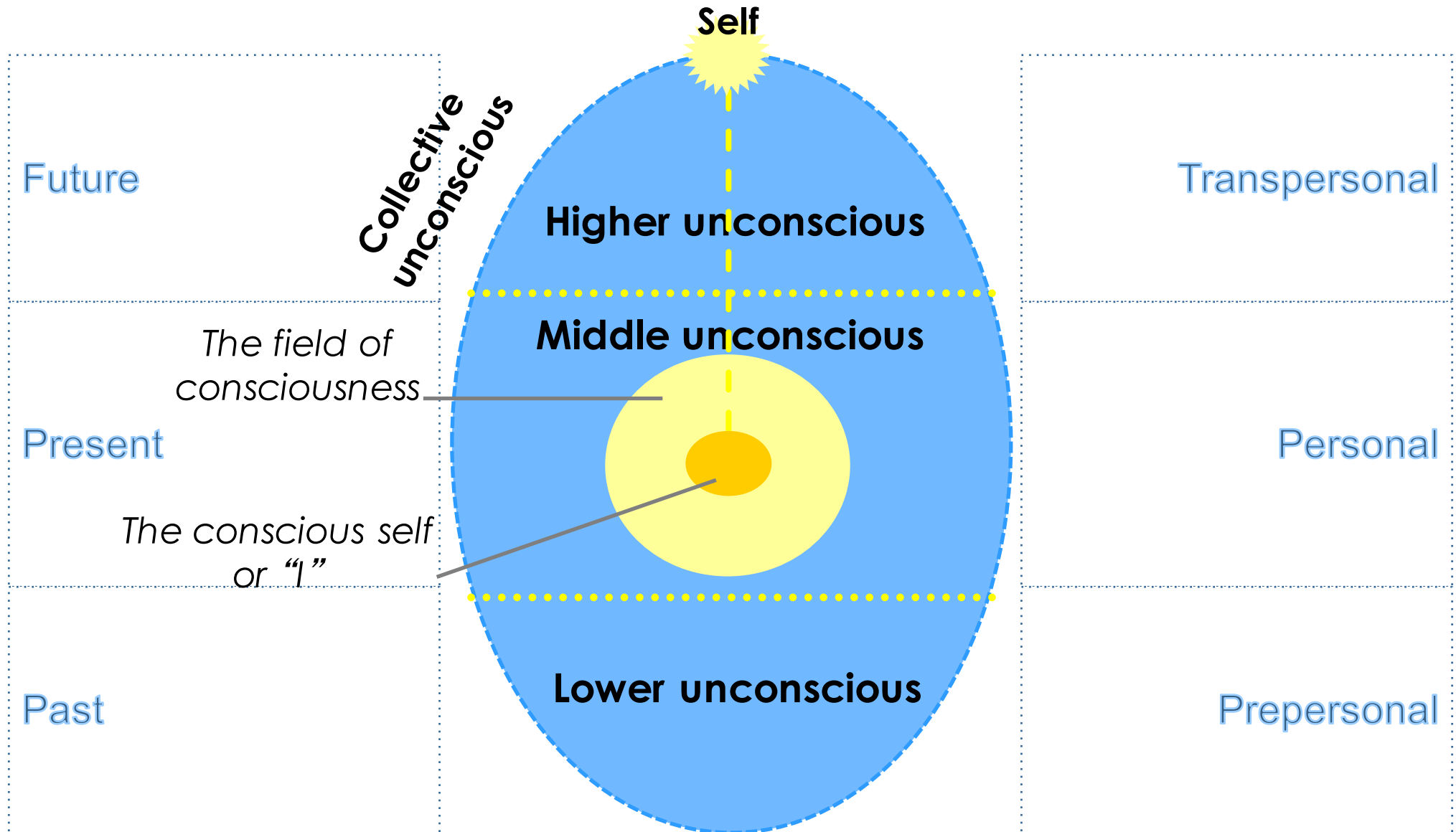

Model of psychospiritual development

Pre-personal, personal and transpersonal levels

- ❖ Prepersonal – *psychoanalytic and psychodynamic psychology*
- ❖ Personal – *humanistic psychology and personality theory*
- ❖ Transpersonal – *transpersonal and psychospiritual psychology*

Basic developmental stages

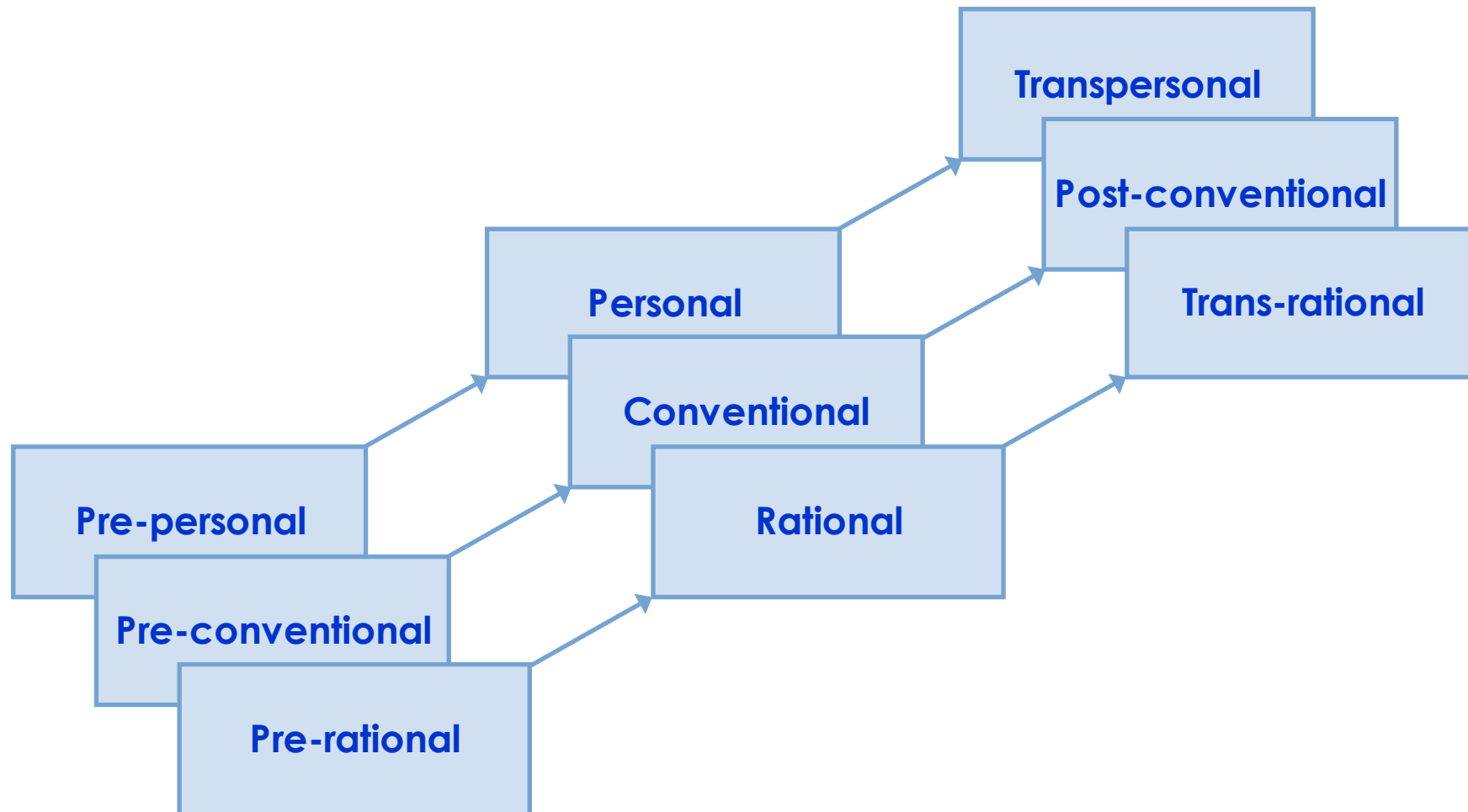

Roberto Assagioli

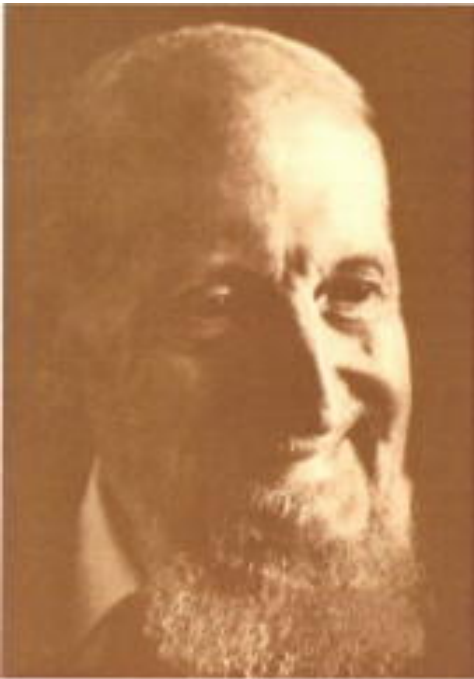

“The basic purpose of psychosynthesis is to release, or let us say, help to release, the energies of the Self. Prior to this the purpose is to help integrate, to synthesize, the individual around the personal self, and then later to effect the synthesis between the personal ego and the Self”

Pre/Trans Fallacy

Paul Elliott



Sequence of Development

From nature to humanity to divine

From subconscious to self-conscious to superconscious

From prepersonal to personal to transpersonal

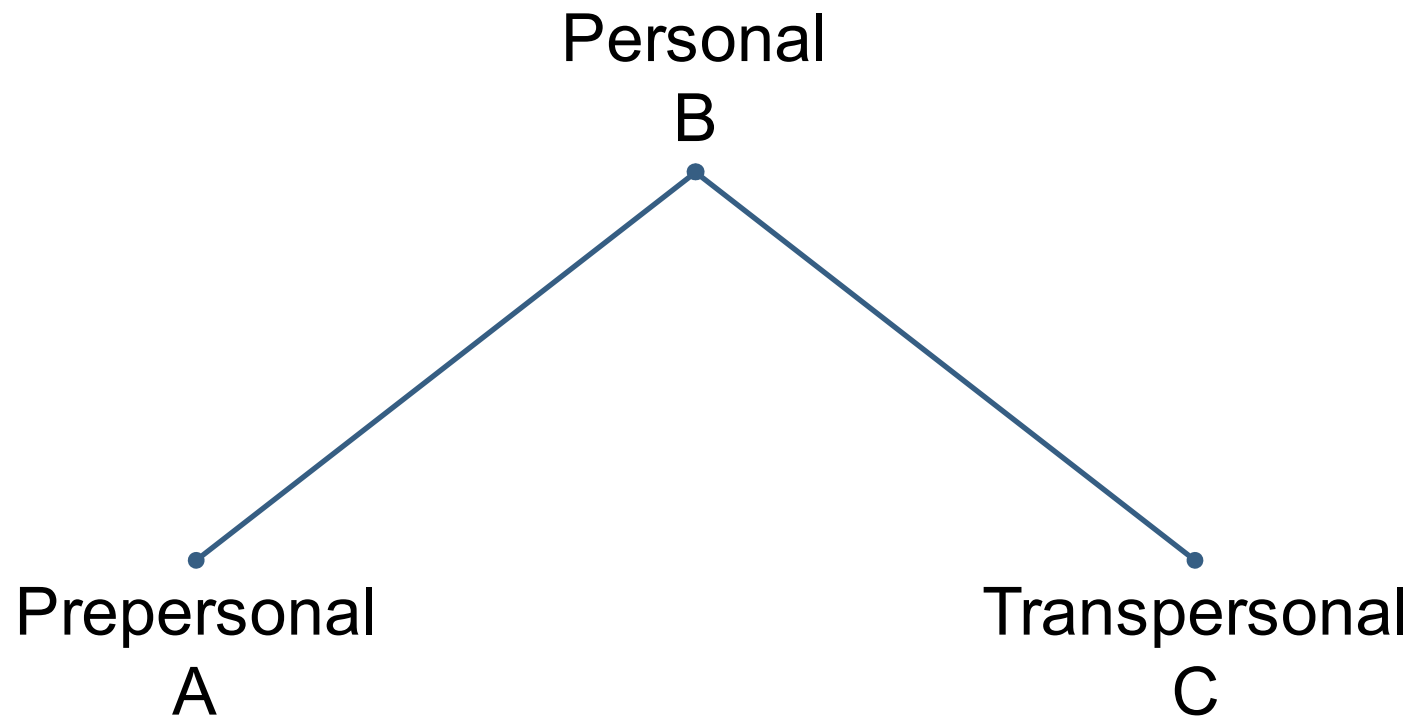

Evolution and Involution (regression)

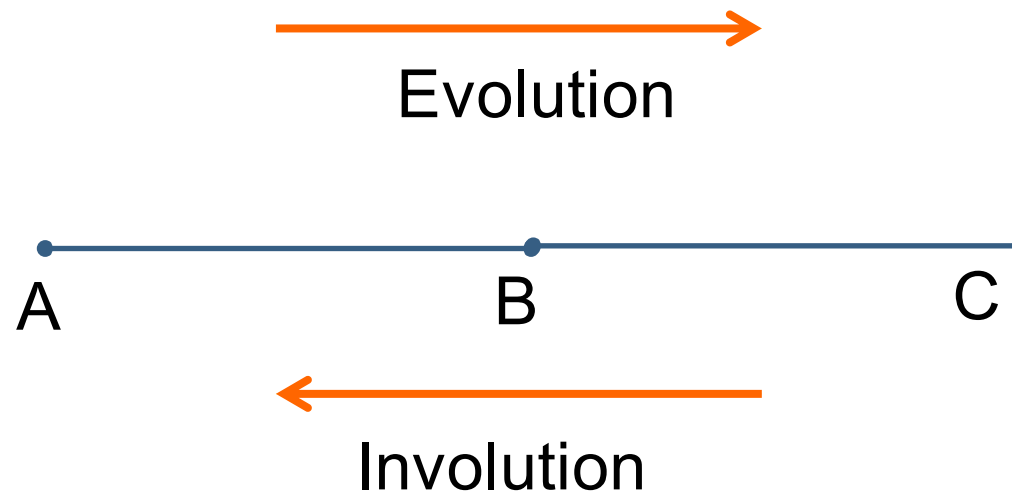

Pre/Trans Fallacy

Ptf 1

- ❖ The transpersonal (C) is collapsed to the prepersonal (A)

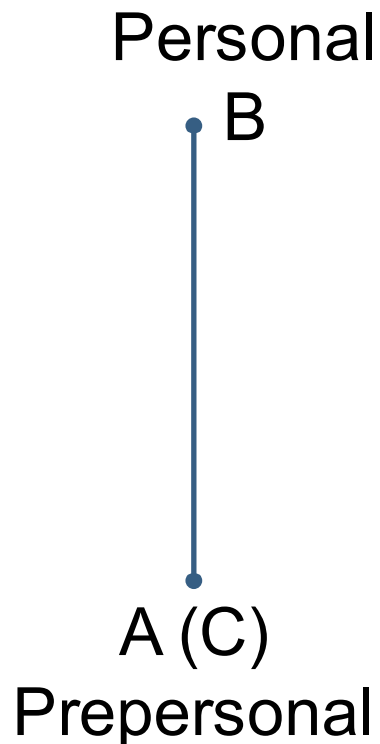

Ptf 2

- ❖ The prepersonal (A) is elevated to the transpersonal (C)

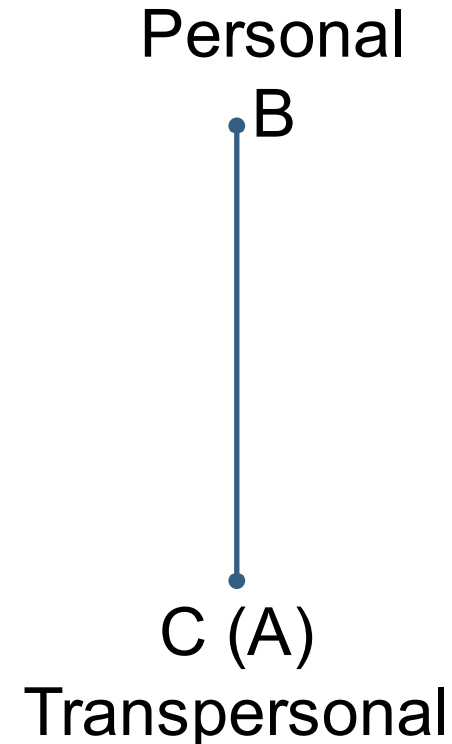

World views from the two pre/trans fallacies

The world view of Ptf 1 (WV-1)

- ❖ The high point of evolution is human rationality
- ❖ Man is a rational being and rationality is all that it needed to comprehend and order the cosmos – orthodox science

The world view of Ptf 2 (WV-2)

- ❖ Development moves from a spiritual source (“in heaven”) to a culmination in a “low point”) of alienation to that of sinful humanity or the individual personal ego
- ❖ History is the history of falling down and not of moving up – orthodox religion

Human Psychological Development and the Pre/trans Fallacy

Ptf 1

- ❖ Freud correctly recognised the prepersonal id (A) and the personal ego (B) but reduced all spiritual and transpersonal experience to (C) the prepersonal level

Ptf 2

- ❖ Jung correctly and explicitly recognises the transpersonal but often fuses it or confuses it with the prepersonal structures
- ❖ For Jung there are only two major realms – ego and Self

Prepersonal

- ❖ Anxiety and neurosis
 - ❖ Attachment behaviour
 - ❖ Transference and counter-transference
 - ❖ Projection and introjection
-
- What are these psychological concepts?
 - Why are they important?
 - How do we recognise them in play?
 - How do we work with them as coaches?
 - Practical work

Anxiety and neurosis

- ❖ Anxiety is derived from the Latin word *angere* – to choke or strangle. It is probably the most important unpleasant feeling that human beings experience. Anxiety is a response to a perceived external danger and produces physiological effects such as pounding of the heart, sweating palms, butterflies in the stomach, rapid breathing etc. Primitive man successfully dealt with anxiety by utilising fight-flight responses.
- ❖ Anxiety can also derive from internal sources within the psyche in the form of subjective, frequently unconscious feelings, fantasies and memories. This ‘neurotic’ anxiety requires more than fight-flight responses so consequently the individual ego develops additional ways to protect itself from these internal threats. The most important of these ego-defences are repression, regression, sublimation and projection.

Attachment behaviour patterns

- ❖ Anxiety, avoidance and attachment patterns of behaviour
- ❖ Personal and professional relationships
- ❖ EQ and emotional regulation
- ❖ Relevance to coaching
 - Self-reflection and psychological mindedness
 - Transference and counter-transference
 - Coaching alliance and positive transference
 - Secure relationship and safe haven

Anxiety and avoidance dimensions

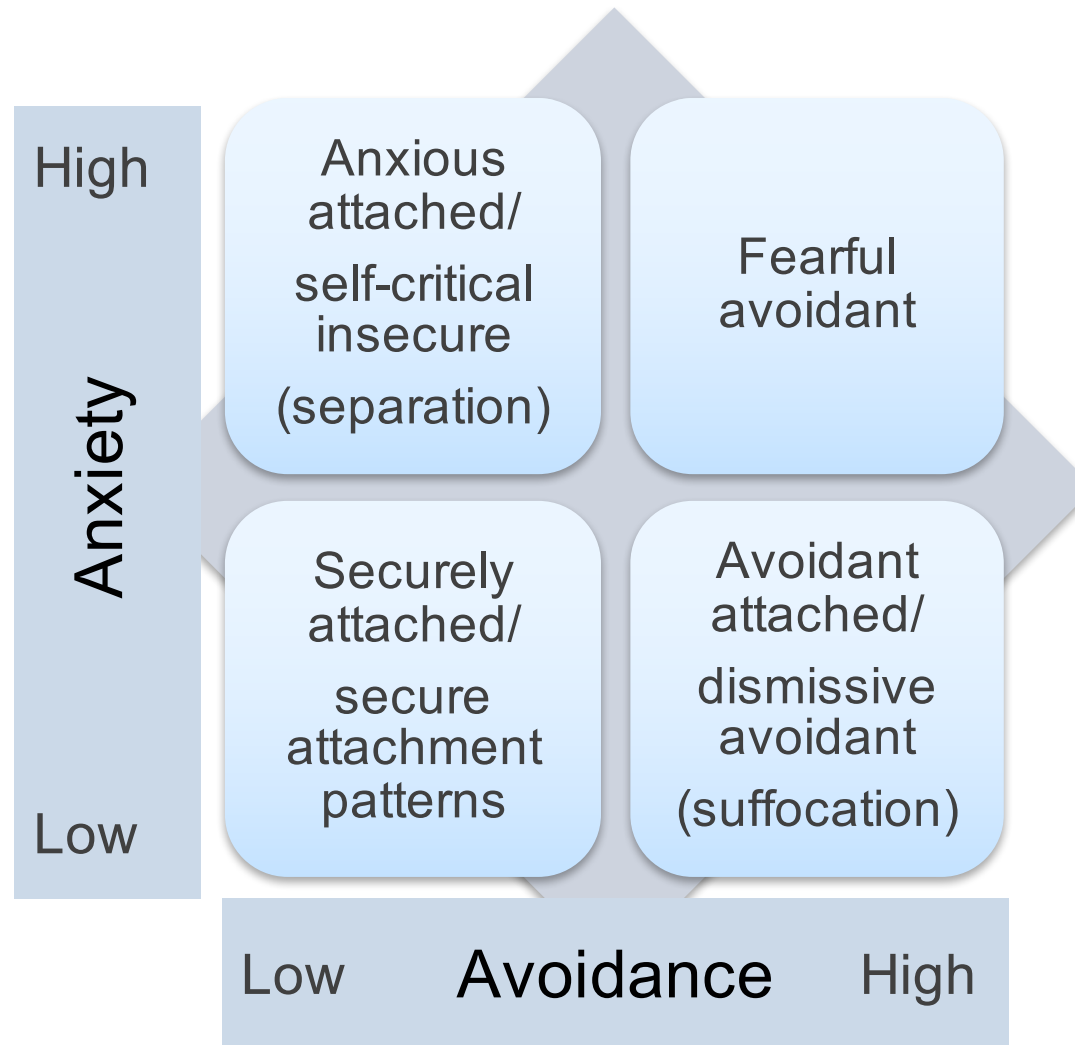

Transference and countertransference

- ❖ Transference manifests as ‘unfinished business’ from the client’s past life which causes the client to distort the present and either misperceive, or behave inappropriately to the coach. Most clients will eventually do this as neurosis indicates that attitudes formed in childhood are inappropriately carried over into adulthood. The coach’s neutrality and relative passivity facilitates transference distortions.
- ❖ Countertransference, on the other hand was first used by Freud in discussing the future prospects of psychoanalysis (1910), and he saw countertransference as a sort of ‘resistance’ in the analyst (in our terms here coach) towards his patient, due to the arousal of unconscious conflicts by what the patient says, does or represents to the analyst.

Projection and introjection

- ❖ **Projection** (German: *Projektion*) was conceptualised by Freud in his letters to Wilhelm Fliess,^[9] and further refined by Karl Abraham and Anna Freud. Freud considered that in projection thoughts, motivations, desires, and feelings that cannot be accepted as one's own are dealt with by being placed in the outside world and attributed to someone else.^[10] What the ego repudiates is split off and placed in another.^[11]
- ❖ Freud would later come to believe that projection did not take place arbitrarily, but rather seized on and exaggerated an element that already existed on a small scale in the other person.^[12]
- ❖ Melanie Klein saw the projection of good parts of the self as leading potentially to over-idealisation of the object.^[15] Equally, it may be one's conscience that is projected, in an attempt to escape its control: a more benign version of this allows one to come to terms with outside authority.^[16]

From Wikipedia, the free encyclopedia

Projective identification

- ❖ **Projective identification** is a term introduced by [Melanie Klein](#) to describe the process whereby in a close relationship, as between mother and child, lovers, or therapist and patient, parts of the self may in unconscious [fantasy](#) be thought of as being forced into the other person.^[1]
- ❖ While based on Freud's concept of [psychological projection](#),^[2] projective identification represents a step beyond. In [R.D. Laing](#)'s words, “The one person does not use the [other](#) merely as a hook to hang projections on. He/she strives to find in the other, or to induce the other to become, the very embodiment of projection”.^[3] Feelings which can not be consciously accessed are [defensively](#) projected into another person in order to evoke the thoughts or feelings projected.^[4]
- ❖ As with [transference](#) and [countertransference](#), projective identification can be a potential key to therapeutic understanding, especially where the therapist is able to tolerate and contain the unwanted, negative aspects of the patient's self over time.^[25]

From Wikipedia, the free encyclopedia

TRANSFERENCE

"A transference of sentiments, drives and conflicts experienced in the past, to current situations and people!"
(Bellak and Faithorn 1981)

TRANSFERENCE

What client projects onto the coach

COUNTERTRANSFERENCE

Everything the coach experiences in the room, including their projections onto the client:

- what the coach experiences as a result of client's projections: "useful countertransference"
- what is evoked in coach's unconscious as a result of client's projections:
"obstructive countertransference": or "my stuff"

RECOGNISING THE NEGATIVE TRANSFERENCE

<u>PROJECTION</u>	<u>NEGATIVE TRANSFERENCE</u>
MEAN, HARSH STRICT, CRITICAL	CRITICAL OR DEMANDING PARENT
USELESS, FAILING DISAPPOINTING, NOT GOOD ENOUGH	ABANDONING OR NEGLECTFUL PARENT
BAD, PUNITIVE, CRUEL	SELF-HATING, INADEQUATE PARENT

GOLDEN RULE!!

- TAKE THE PROJECTION
- DON'T TRY TO JUSTIFY YOURSELF OR MAKE YOURSELF LOOK BETTER IN COACHEE'S EYES

TAKING THE PROJECTION

<u>PROJECTION</u>	<u>TAKING THE PROJECTION</u>
MEAN, HARSH, STRICT, CRITICAL	"I FEEL <u>AS IF</u> I'M BEING UNDULY HARD ON YOU"
USELESS, FAILING, DISAPPOINTING, NOT GOOD ENOUGH	"I FEEL <u>AS IF</u> I'VE FAILED YOU/ DISAPPOINTED YOU/ NOT MEASURED U TO YOUR EXPECTATIONS"

POSITIVE TRANSFERENCE

Projections from client create good, positive, proactive feelings in the coach: this indicates POSITIVE TRANSFERENCE: it can be left alone.

NEGATIVE TRANSFERENCE

Client projections create extreme, difficult or unwanted feelings in coach: these call for conscious attention from the coach.

IMPLICATIONS FOR THE COACH

- COACH MUST PRACTISE SELF-AWARENESS
- COACH SHOULD BE FAMILIAR WITH 'HER STUFF' (HER OWN TYPICAL 'OBSTRUCTIVE COUNTERTRANSFERENCE')

TWO GOLDEN RULES!

- DON'T TAKE IT PERSONALLY
- DON'T GET DEFENSIVE
- STAY CONNECTED TO YOUR SENSE OF PURPOSE

Projection and ownership by the client

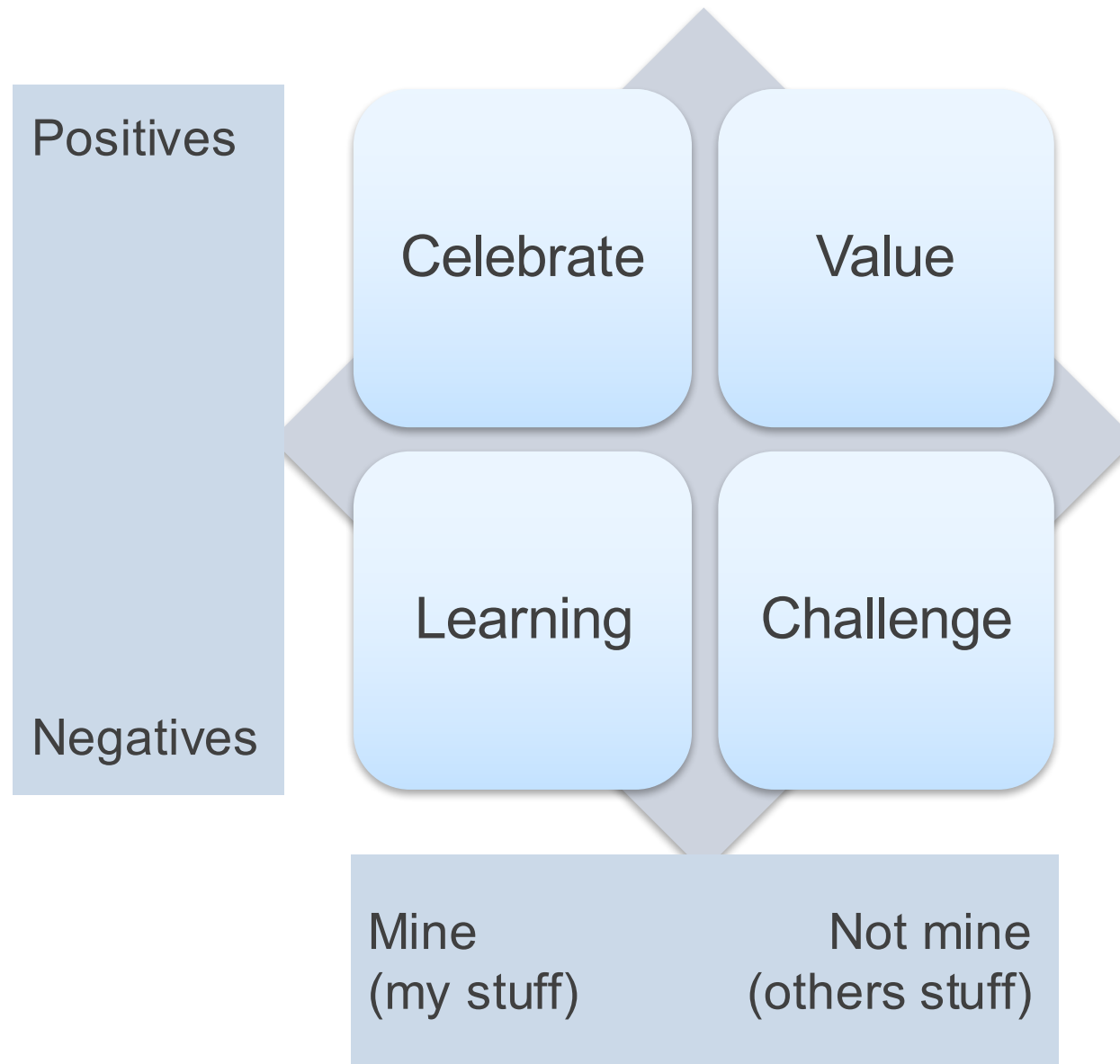

Working with prepersonal material – practice session in triads

- ❖ Forms groups of three - 30 mins per segment
 - 20 mins session
 - 10 mins debrief
- ❖ Coach
 - Hold Trifocal Vision
 - Work with the coachee on a relationship issue of their choosing
- ❖ Coachee
 - Bring a real current relationship issue that you would like to work on
- ❖ Observer
 - Also hold Trifocal Vision
 - Reflect upon the pre-personal dynamics within the relationship issue, as well as on secondary process – the dynamics playing out between coach and coachee

Check-out

- ❖ Brief inner reflection
- ❖ Check-out

Day Two

❖ Check-in and reflection

Academic briefing

- ❖ PGCPCL requirements and procedures
- ❖ Certification – Institute of Psychosynthesis
- ❖ Qualification – Middlesex University
- ❖ Accreditation – APECS (Fast Track)

Paper titles

Journal reflection

- ❖ *With reference to your reflective journal, describe your experience of self-exploration and developing self-awareness so far during this course. How is your ability as a coach improving and how does your learning about yourself inform your understanding of others?*
- ❖ 2,500 Words

Written paper

- ❖ *How does psychosynthesis coaching address the emerging challenges of leadership within today's organisations? In what ways do psycho-spiritual, developmental and systemic perspectives enhance the leadership coach's ability to support the development of leaders?*
- ❖ 5,000 Words

Personal/humanistic

- ❖ The personal level of consciousness
- ❖ Jung and personality type
- ❖ The emergence of humanistic psychology
- ❖ Carl Rogers and person-centred approaches
- ❖ Abraham Maslow – humanistic and transpersonal psychology
- ❖ Introduction to TA, Gestalt Psychology and NLP
- ❖ Positive Psychology and Neuro-psychology
- ❖ Integration within the Psychosynthesis context

TA Ego-states model

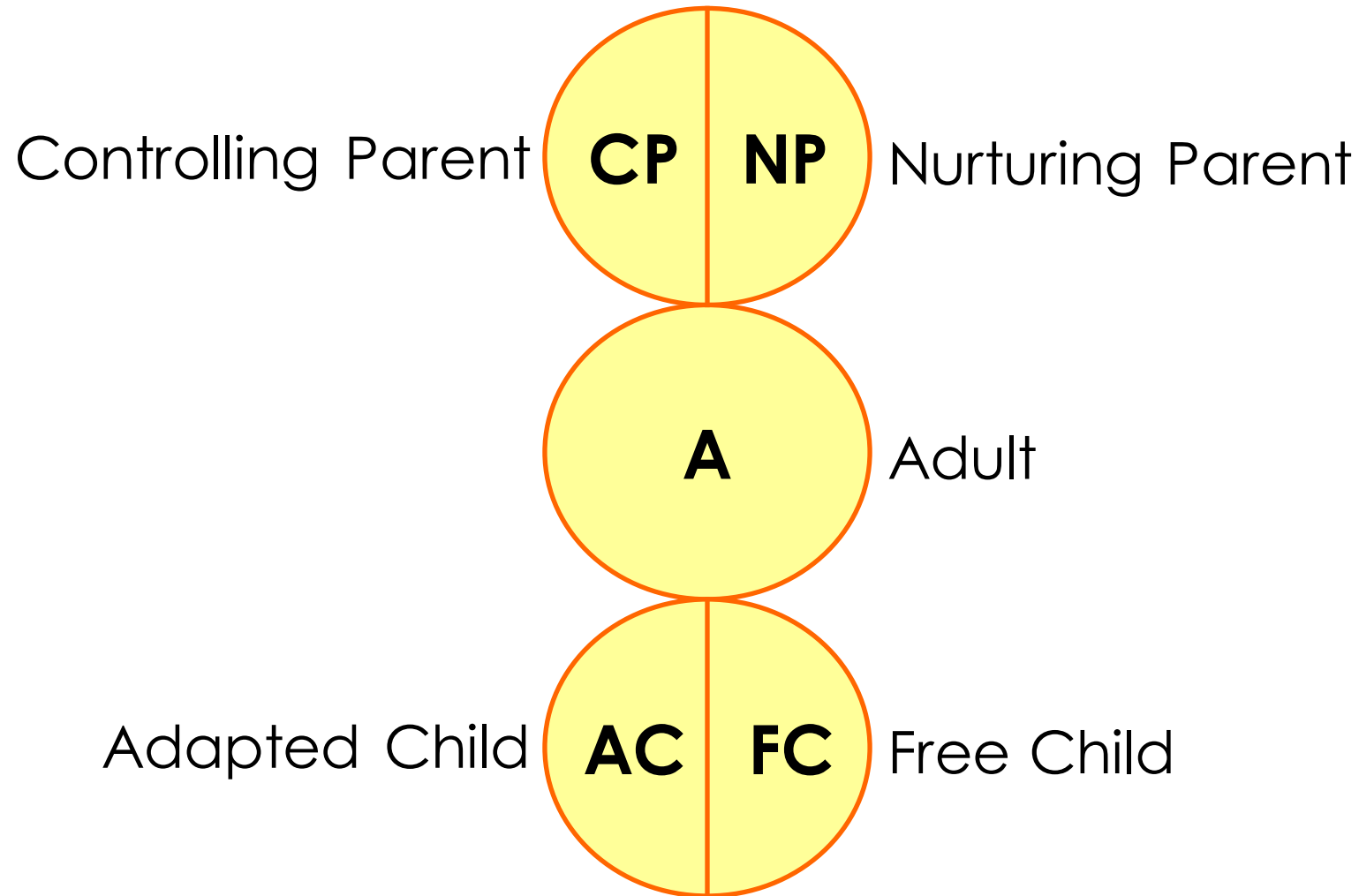

TA Ego-states model and Transaction

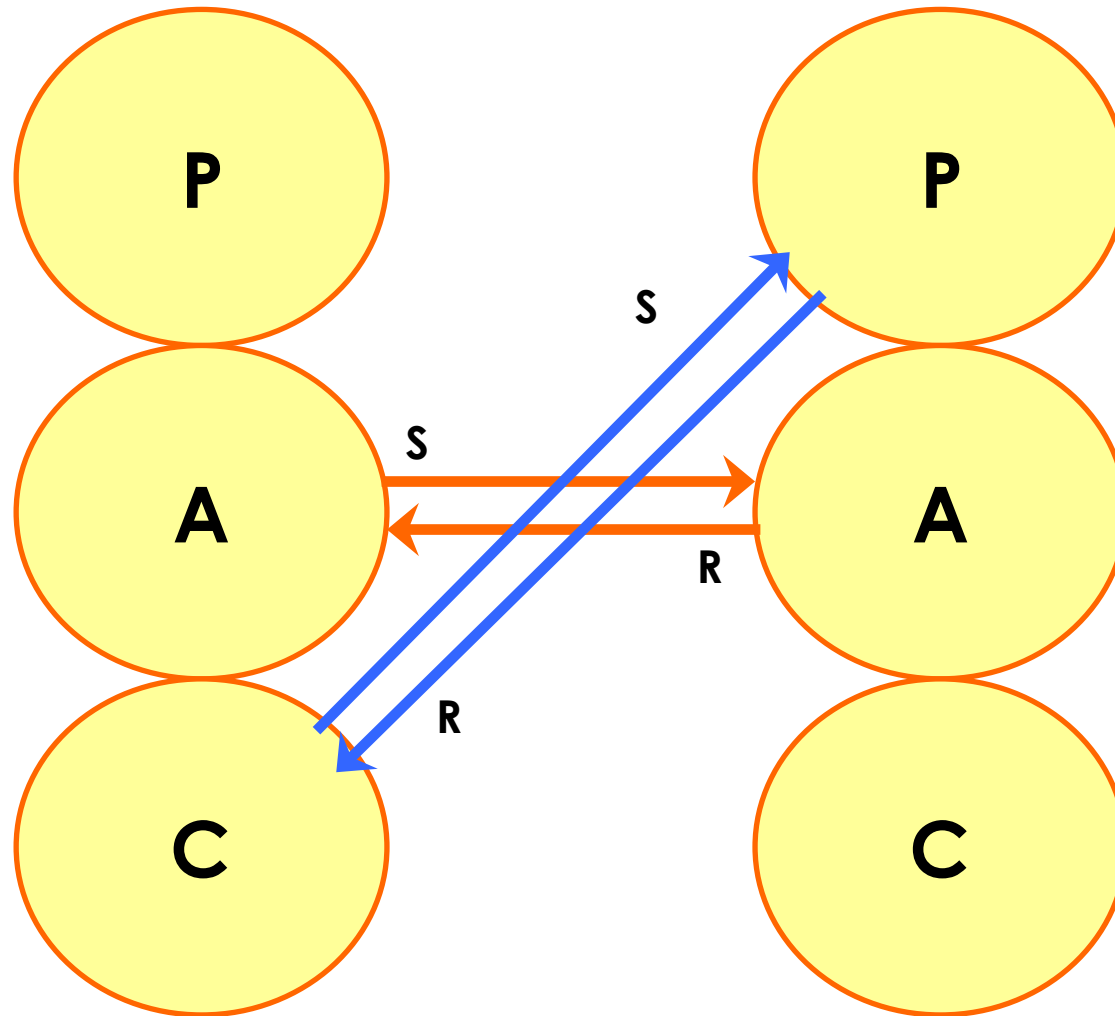

TA - The Drama Triangle

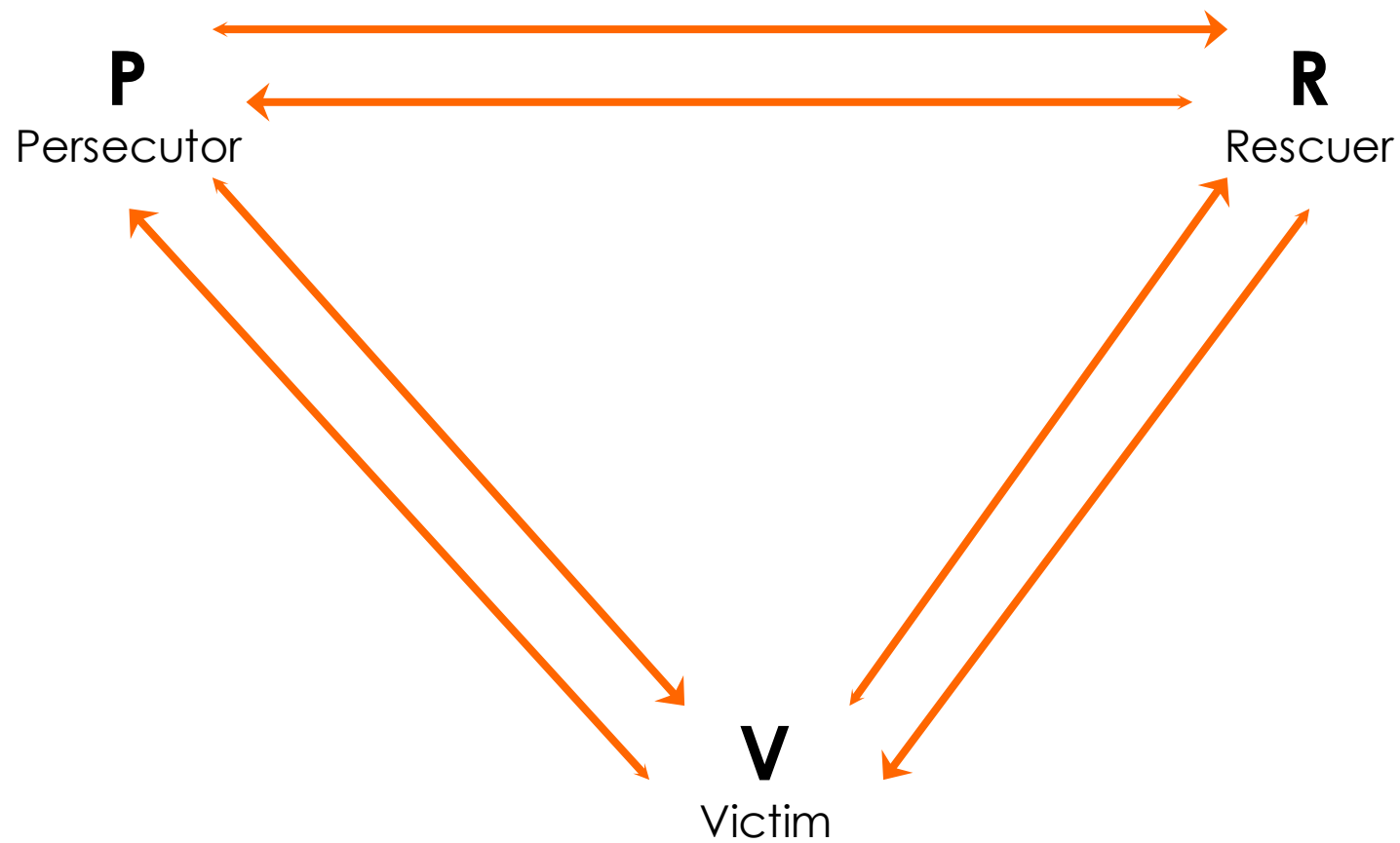

TA - Drivers

- ❖ Be perfect
- ❖ Please (others)
- ❖ Try Hard
- ❖ Be Strong
- ❖ Hurry Up

Gestalt – fundamental propositions

- ❖ That awareness leads to change
- ❖ That the aim of the coach is to help clients to become more aware of their own process
- ❖ That this heightened awareness will produce a greater understanding of what is needed, what choices are open, and will ultimately produce more effective decision making and action
- ❖ That the awareness raising process produces greater personal ownership and responsibility
- ❖ That our emerging dominant needs organise our field of perception
- ❖ That we perceive in whole and seek to gain closure around issues
- ❖ That we need to give meaning to our perceptions and experiences
- ❖ That learning occurs through the examination of here and now experiences

Peter Bluckert – Psychological Dimensions of Executive Coaching

Gestalt cycle of experience

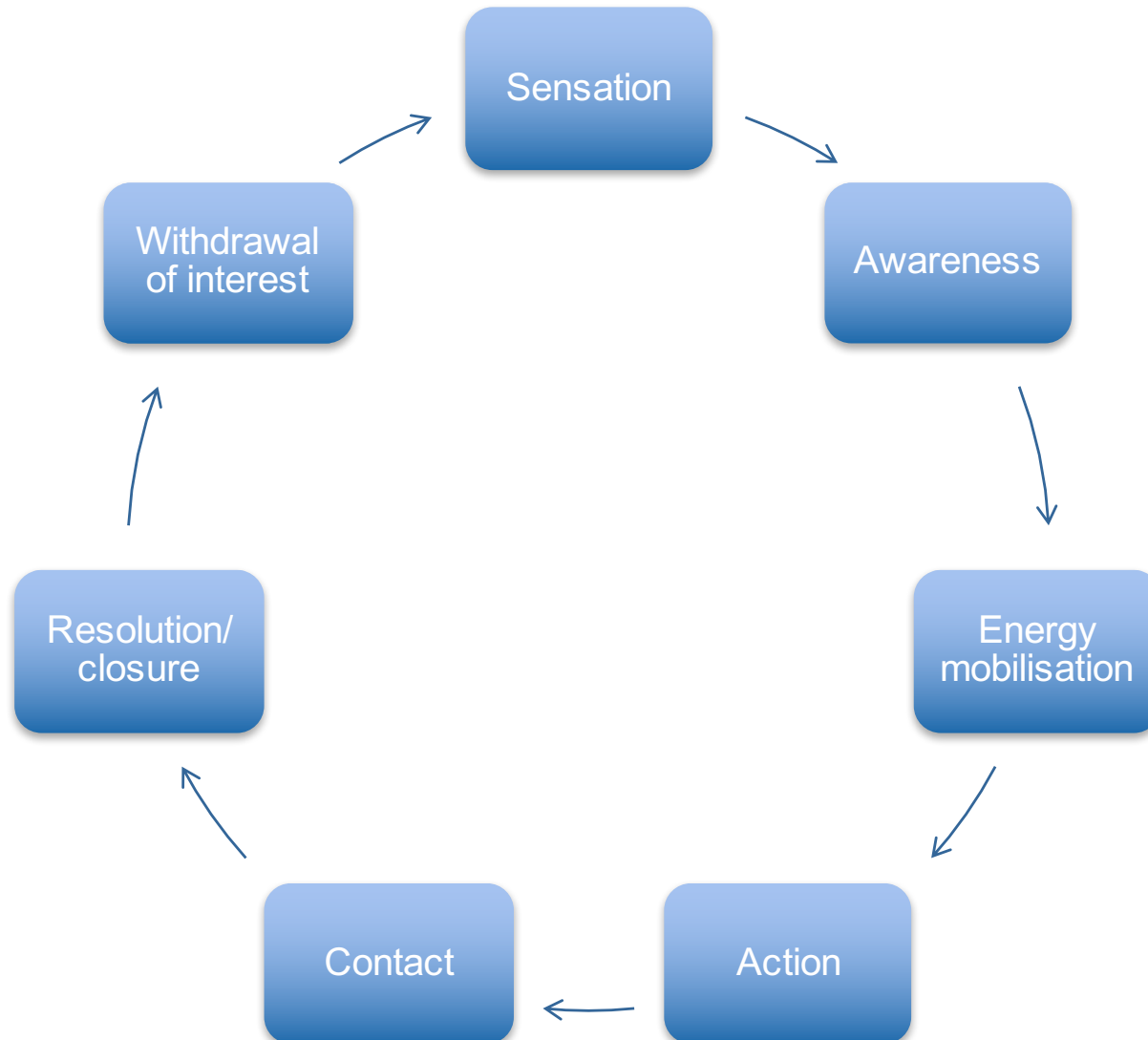

Gestalt cycle – neurosis analysis

Stage	Neurosis	Remedy
Sensation	<i>Desensitisation</i>	Feel
Awareness	<i>Deflection</i>	Listen
Energy mobilisation	<i>Introjection</i>	Communicate
Action	<i>Projection</i>	Own
Contact	<i>Retroflection</i>	Engage
Resolution	<i>Egotism</i>	Acknowledge
Withdrawal	<i>Confluence</i>	Reflect

Group Session – Gestalt facilitation

- ❖ Awareness
- ❖ Here and now
- ❖ Group process
- ❖ Emerging needs
- ❖ Cycle of experience

Positive Psychology and Coaching

Paul Elliott



Strength vs Weaknesses

- ❖ According to One World 10th Annual Coaching Survey (2015) there are two schools of thought in coaching:
 - One involves identifying and working on strengths
 - Work on increasing positive emotions and positive traits building a body of coaching materials to enhance people's happiness
 - The other involves identifying and correcting weaknesses
 - Assumes your strengths have got you where you are. Dealing with weakness in behaviour is the only way to get to the next level

Which approach is most widely used?

Global Uses of Coaching Approaches

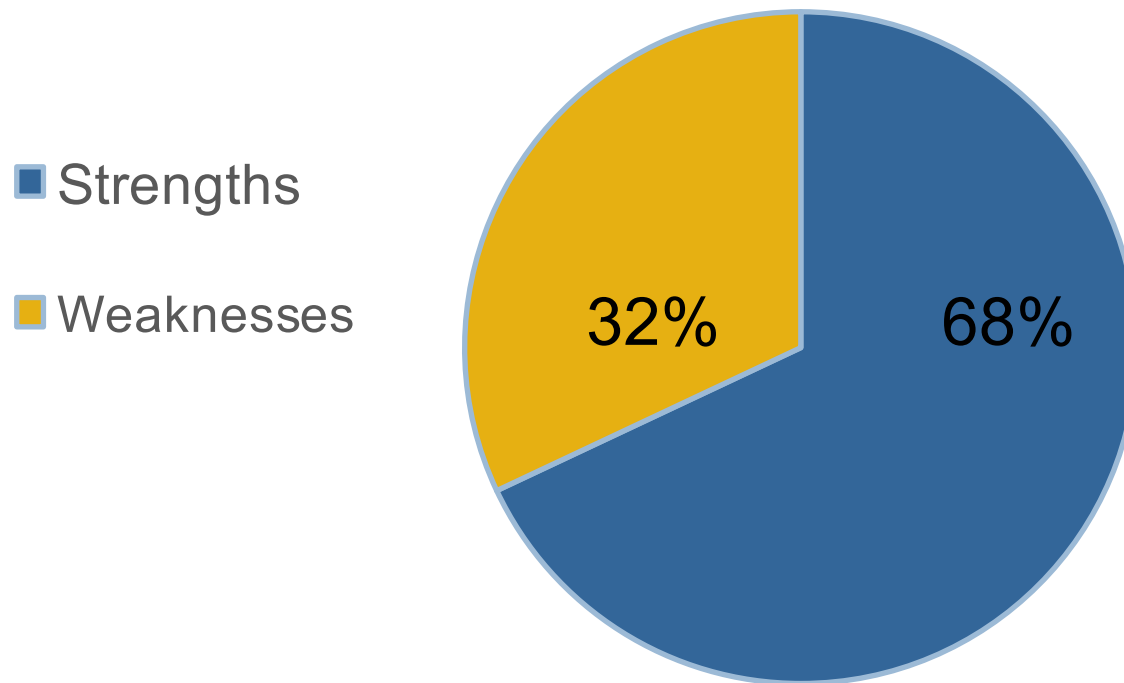

One World 10th Annual Coaching Survey

The Foundation of Positive Psychology Coaching

- ❖ Strength-Based Coaching –focusing on individuals signature characteristic strengths and operating at peak performance
 - Seligman and Csikszentmihalyi

Strength Based Coaching

- ❖ Strength based coaching is about finding the coachee's top Signal characteristic strengths (SCS) and working with the coachee to build on those strengths
- ❖ A strength profile can be done on line www.viacharacter.org and was established to advance the science and practice of character strengths.
- ❖ There are 6 SCS dimensions and 24 SCS dimensions (hand out)
- ❖ According to Positive Psychology: “ these signature strengths represent your sweet spot for growth and engagement. They are the *best of the best* in you and you own them!” (VIA Institute on Character)

Exercise: What are your Signature Characteristic Strengths (SCS) ?

- ❖ Remember the last time you felt extremely happy and engaged in an activity
 - What were you doing
 - How did it feel?
 - Who else was involved?

- ❖ Looking at the list of SCS domains and elements, which would you consider to be the top 5 elements for you?

Positive Psychology coaching in Psychosynthesis context

- ❖ What does this add to Psychosynthesis Leadership Coaching?
- ❖ How does this help with holding Trifocal vision?
- ❖ What is missing?

Check-out

- ❖ Brief inner reflection
- ❖ Check-out

Day Three

❖ Check-in and reflection

What is the Transpersonal?

- ❖ Purpose
- ❖ Meaning
- ❖ Values
- ❖ Identity
- ❖ Being
- ❖ Presence
- ❖ Potential
- ❖ Emergent
- ❖ Heart and Soul
- ❖ Will
- ❖ Self
- ❖ Imagination
- ❖ Intuition
- ❖ Spirit
- ❖ Evolutionary
- ❖ *Meta-needs*
- ❖ *Ultimate values*
- ❖ *Unitive consciousness*
- ❖ *Peak experiences*
- ❖ *Ecstasy*
- ❖ *Mystical experience*
- ❖ *Being values*
- ❖ *Essence*
- ❖ *Bliss*
- ❖ *Awe*
- ❖ *Wonder*
- ❖ *Self-actualisation*
- ❖ *Ultimate meaning*
- ❖ *Transcendence of the self*
- ❖ *Spirit*

Overview of psychospiritual and transpersonal psychologies

- ❖ Jung
- ❖ Maslow
- ❖ Assagioli
- ❖ Journal of Transpersonal Psychology
- ❖ Groff
- ❖ Heron
- ❖ Wilber
- ❖ Ferrer

What is psychosynthesis?

- ❖ Psychosynthesis was developed by **Roberto Assagioli** (1888 – 1974). Some of the things he said:
- ❖ “The basic purpose of psychosynthesis is to release, or let us say, help to release, the energies of the Self. Prior to this the purpose is to help integrate, to synthesize, the individual around the personal self, and then later to effect the synthesis between the personal ego and the Self”
- ❖ “We pay far more attention to the higher unconscious and to the development of the transpersonal self. In one of his letters Freud said, "I am interested only in the basement of the human being." Psychosynthesis is interested in the whole building. We try to build an elevator which will allow a person access to every level of his personality. After all, a building with only a basement is very limited. We want to open up the terrace where you can sun-bathe or look at the stars. Our concern is the synthesis of all areas of the personality. That means psychosynthesis is holistic, global and inclusive”

Transpersonal – working with the Self in coaching

- ❖ Self calls
- ❖ Peak experiences
- ❖ Crisis of meaning
- ❖ Crisis of duality
- ❖ Breakdown and breakthrough
- ❖ Emergence
- ❖ Emergency
- ❖ Symptoms
- ❖ Developmental journey

Working with Self and crisis in coaching – practice session in triads

- ❖ Form groups of two or three - 30 mins for one segment
 - 25 mins session
 - 5 mins debrief
- ❖ Coach
 - Hold Trifocal Vision
 - Working with crisis, helping the client with sense making
- ❖ Coachee
 - Explore an experience of Self calling in your life – perhaps a crisis of meaning or duality, or a peak experience of some kind – either current or from the past, with a view to making sense of it in terms of your personal journey or awakening
- ❖ Observer
 - Also hold Trifocal Vision
 - Observe what happens, reflect upon how crisis informs us, notice any secondary process

Transpersonal – working with the Will in coaching

- ❖ Aspects and qualities of Will
- ❖ Will and the psychological functions
- ❖ The act of Will
- ❖ Working with Will in coaching – Trifocal Vision

Aspects of Will



Will and the psychological functions

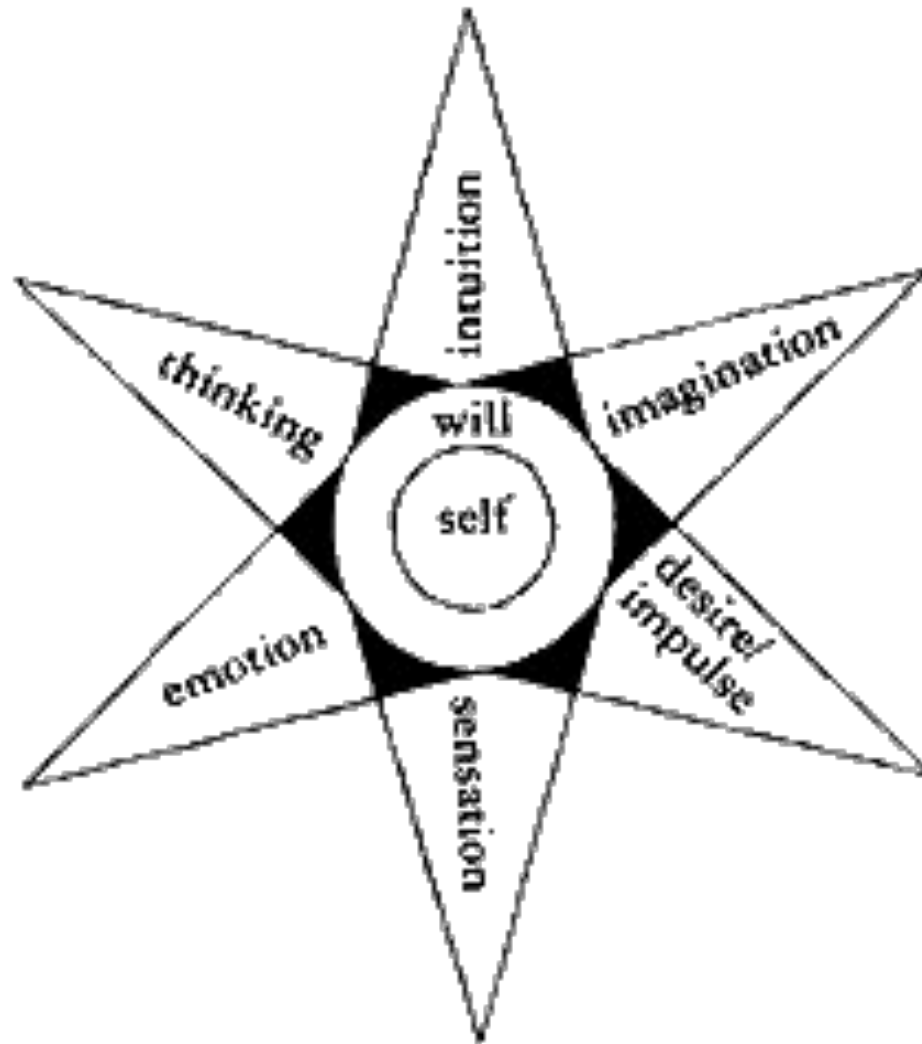

Qualities of Will

**Energy/
intensity**

**Mastery/
discipline**

**Focus/
attention**

**Determination/
resoluteness**

**Persistence/
patience**

**Initiative/
courage**

**Integration/
synthesis**

Creative Expression – The Act of Will

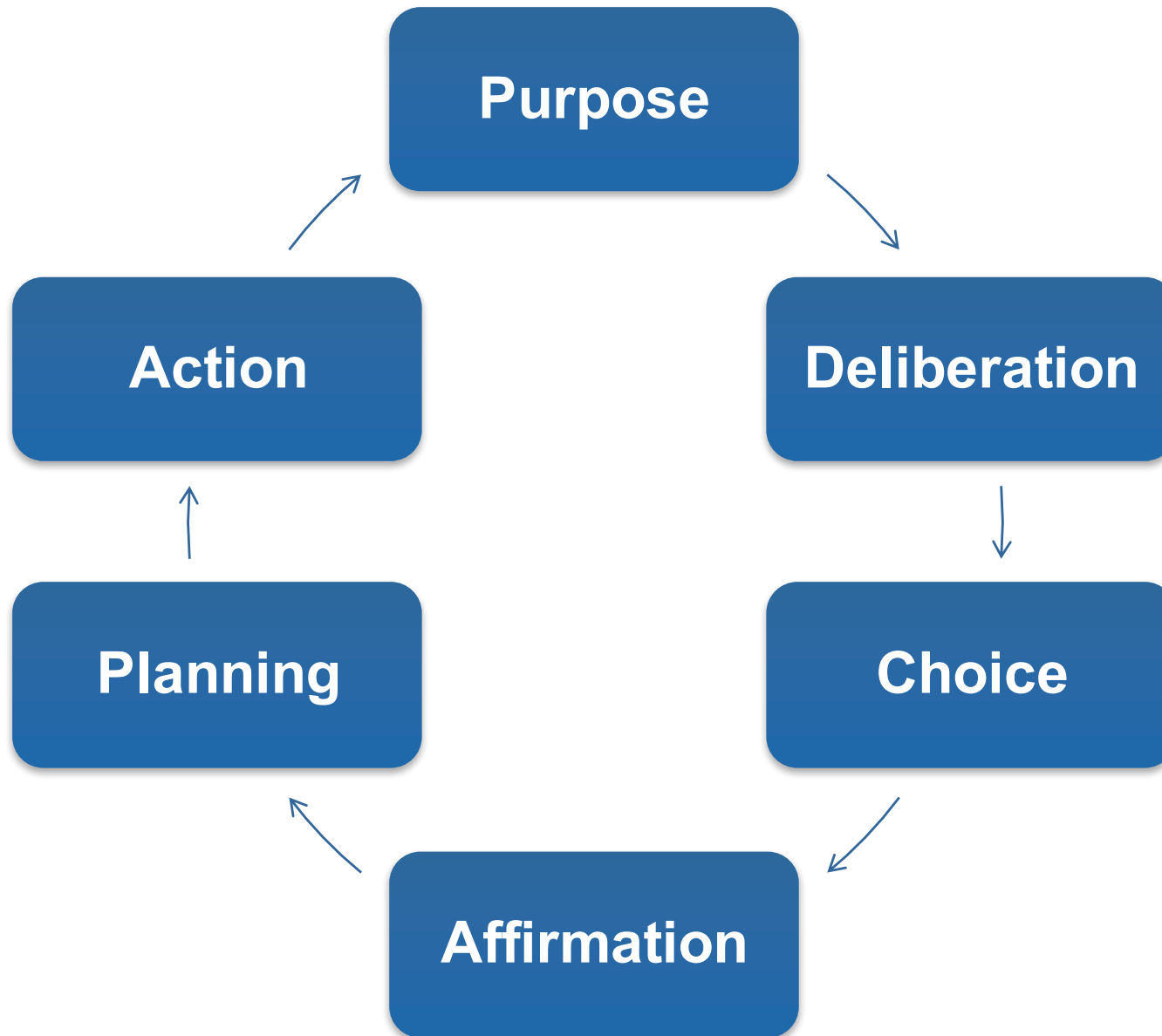

Creative Expression – The Act of Will

	<i>Will</i>	<i>Consciousness</i>	<i>Matter</i>
	<i>Spirit</i>	<i>Soul</i>	<i>Body</i>
<i>Self/ Transpersonal Will</i>	Purpose	Meaning	Values
<i>I/ Personal Will</i>	Intention	Deliberation	Choice
<i>Ego/ Pre-personal Will (desires, impulses)</i>	Affirmation	Planning	Action



Working with Will – practice

Fishbowl coaching session

- ❖ Client
- ❖ Plus three chairs

Coaches

- ❖ Helping the client to find and release available will in relation to their issue
- ❖ Stepping in and stepping out

Client

- ❖ Bring an area of your life where you are stuck and want to make something happen

Observers

- ❖ Reflect upon what works to find and release available will
- ❖ Reflect upon use of coaching skills
- ❖ Reflect upon any secondary process

Homework

- ❖ Journal – reflective essay
- ❖ Study guide
- ❖ Peer coaching
- ❖ Supervision session

Check-out

- ❖ Experience of the weekend
- ❖ Take away from this weekend
- ❖ A goal for the next month

Completion

